

INSTALLATION INSTRUCTIONS FOR DUAL-FLUSH FLUSHOMETERS



WES-111
Exposed Closet
Flushometer
for 1-1/2 Top Spud

EXPOSED TOP SPUD 1½" WATER CLOSET

- MODEL 111
- MODEL 113
- MODEL 115
- MODEL 116

EXPOSED REAR SPUD 1½" WATER CLOSET

- MODEL 120

LIMITED WARRANTY

Unless otherwise noted, Sloan Valve Company warrants this product, manufactured and sold for commercial or industrial uses, to be free from defects in material and workmanship for a period of three (3) years (one (1) year for special finishes, SF faucets, PWT electronics and 30 days for PWT software) from date of first purchase. During this period, Sloan Valve Company will, at its option, repair, replace, or refund the purchase price of any product which fails to conform with this warranty under normal use and service. This shall be the sole and exclusive remedy under this warranty. Products must be returned to Sloan Valve Company, at customer's cost. No claims will be allowed for labor, transportation or other costs. This warranty extends only to persons or organizations who purchase Sloan Valve Company's products directly from Sloan Valve Company for purpose of resale. This warranty does not cover the life of the batteries.

THERE ARE NO WARRANTIES WHICH EXTEND BEYOND THE DESCRIPTION ON THE FACE HEREOF. IN NO EVENT IS SLOAN VALVE COMPANY RESPONSIBLE FOR ANY CONSEQUENTIAL DAMAGES OF ANY MEASURE WHATSOEVER.

PRIOR TO INSTALLATION

Before you install the flushometer, be sure the items listed below are installed. Also, refer to the rough-in diagram below.

- Closet fixture
- Drain line
- Water supply line

IMPORTANT:

- **ALL PLUMBING SHOULD BE INSTALLED IN ACCORDANCE WITH APPLICABLE CODES AND REGULATIONS.**

- **WATER SUPPLY LINES MUST BE SIZED TO PROVIDE AN ADEQUATE VOLUME OF WATER FOR EACH FIXTURE.**
- **FLUSH ALL WATER LINES PRIOR TO MAKING CONNECTIONS.**

Sloan's flushometers are designed to operate with 10 to 100 psi (69 to 689 kPa) of water pressure. **THE MINIMUM PRESSURE REQUIRED TO THE VALVE IS DETERMINED BY THE TYPE OF FIXTURE SELECTED.** Consult fixture manufacturer for minimum pressure requirements. Most Low Consumption water closets (1.6 gpf/6.0 Lpf) require a minimum flowing pressure of 25 psi (172 kPa).

TOOLS REQUIRED FOR INSTALLATION

- Straight blade screwdriver
- Sloan A-50 Super-Wrench™, Sloan A-109 Plier Wrench or smooth jawed spud wrench

ROUGH-IN

MODELS 111, 113, 114, 115, 116

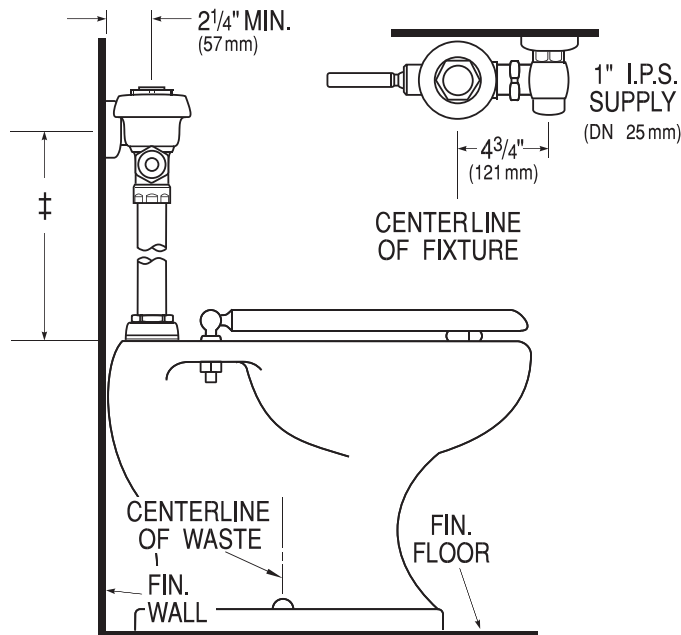

- | | |
|-----------------------------|--------------------------|
| ‡ Model 111 – 11½" (292 mm) | Model 115 – 24" (610 mm) |
| Model 113 – 16" (406 mm) | Model 116 – 27" (686 mm) |
| Model 114 – 34⅜" (873 mm) | |

MODEL 120

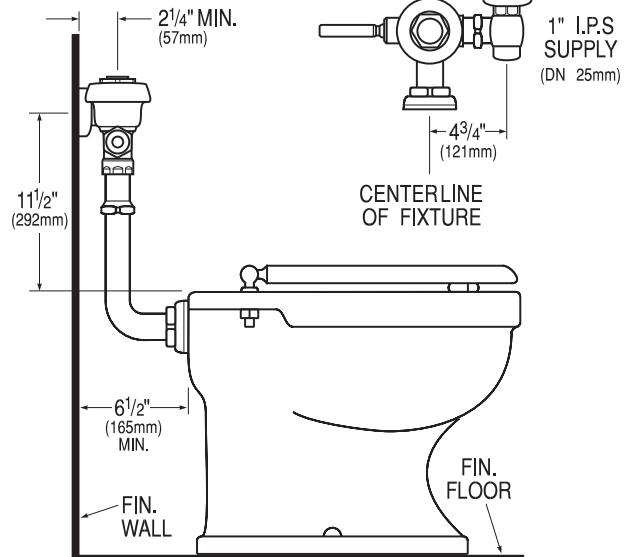

!!! IMPORTANT !!!

Protect the chrome or special finish of Sloan Flushometers – **DO NOT USE** toothed tools to install or service these valves. Use a Sloan A-50 Super-Wrench™, Sloan A-109 Plier Wrench or smooth jawed spud wrench to secure all couplings. Also see "Care and Cleaning" section of this manual.

!!! IMPORTANT !!!

This product contains mechanical and/or electrical components that are subject to normal wear. These components should be checked on a regular basis and replaced as needed to maintain the valve's performance.

!!! IMPORTANT !!!

When mounted on an ADA accessible bowl, the rough-in to the supply inlet should be no higher than 37½" or the handle will exceed maximum height allowances under ADA guidelines.

New ADAAG Guidelines allow for Split or Offset Grab Bars, check with local authorities or reference section 604.5.2 of ADAAG.

1 - INSTALL OPTIONAL SWEAT SOLDER ADAPTER (ONLY IF YOUR SUPPLY PIPE DOES NOT HAVE MALE THREAD)

A Measure from finished wall to C/L of fixture spud. Cut pipe 1" (32 mm) shorter than this measurement. Chamfer O.D. and I.D. of water supply pipe.

B Slide threaded adapter fully onto pipe.

C Sweat solder the adapter to pipe.

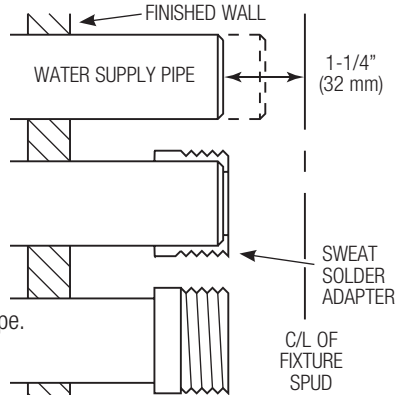

!!! IMPORTANT !!!
WITH THE EXCEPTION OF THE CONTROL STOP INLET, DO NOT USE PIPE SEALANT OR PLUMBING GREASE ON ANY VALVE COMPONENT OR COUPLING!

A Measure from finished wall to first thread of adapter or threaded supply pipe (dimension "X"). Cut cover tube to this length.

B Slide cover tube over pipe. Slide wall flange over cover tube until against wall.

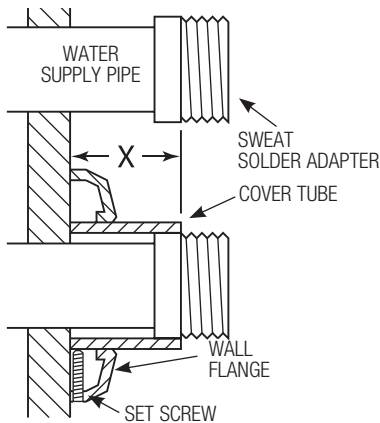

C Thread Control Stop onto pipe. Tighten with a wrench.

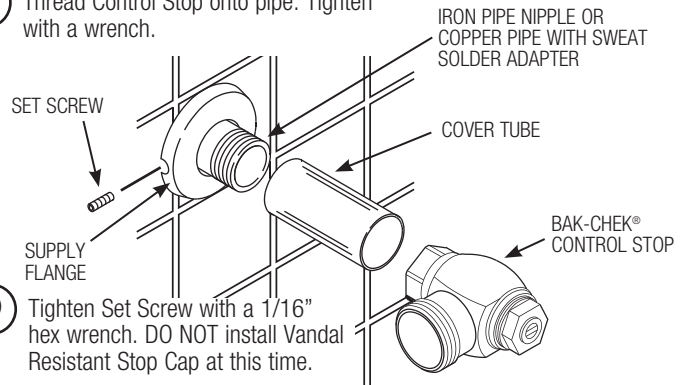

D Tighten Set Screw with a 1/16" hex wrench. DO NOT install Vandal Resistant Stop Cap at this time.

3 - INSTALL VACUUM BREAKER CONNECTION

A Slide spud coupling, nylon slip gasket, rubber gasket and spud flange over vacuum breaker tube.

B Insert tube into fixture spud.

C Hand tighten spud coupling onto fixture spud.

NOTE

Follow instructions on bag of high back pressure vacuum breaker kit included with flushometer: insert baffle into groove of vacuum breaker sack; insert sack in vacuum breaker tube; and place friction ring on top of sack.

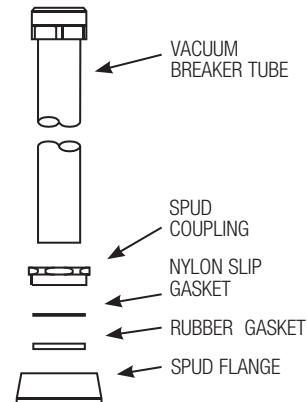

4 - INSTALL FLUSHOMETER

A Lubricate tailpiece o-ring with water. Insert adjustable tailpiece into control stop. Tighten tailpiece coupling by hand.

B Align flushometer directly above the vacuum breaker flush connection by sliding the flushometer body IN or OUT as needed. Tighten vacuum breaker coupling by hand.

C Align flushometer body and securely tighten first the tailpiece coupling (1), then the vacuum breaker coupling (2), and finally the spud coupling (3). Use a wrench to tighten these couplings in the order shown.

NOTE

MAXIMUM adjustment of Sloan adjustable tailpiece is 1/2" (13 mm) IN or OUT from the standard 4 3/4" (121 mm) (centerline of flushometer to centerline of control stop).

If roughing-in measurement exceeds 5 1/4" (133 mm), a longer tail may be supplied.

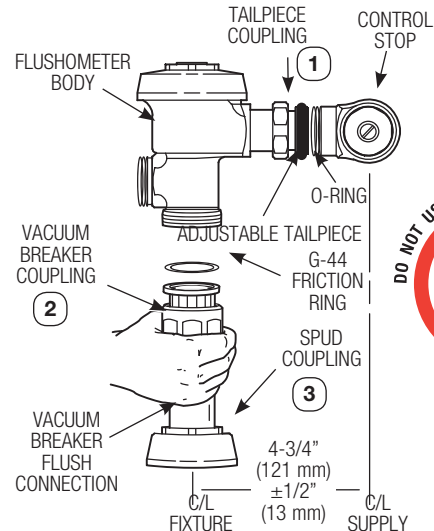

5 - INSTALL DUAL-FLUSH HANDLE ASSEMBLY AND GASKET (IF NOT ALREADY INSTALLED)

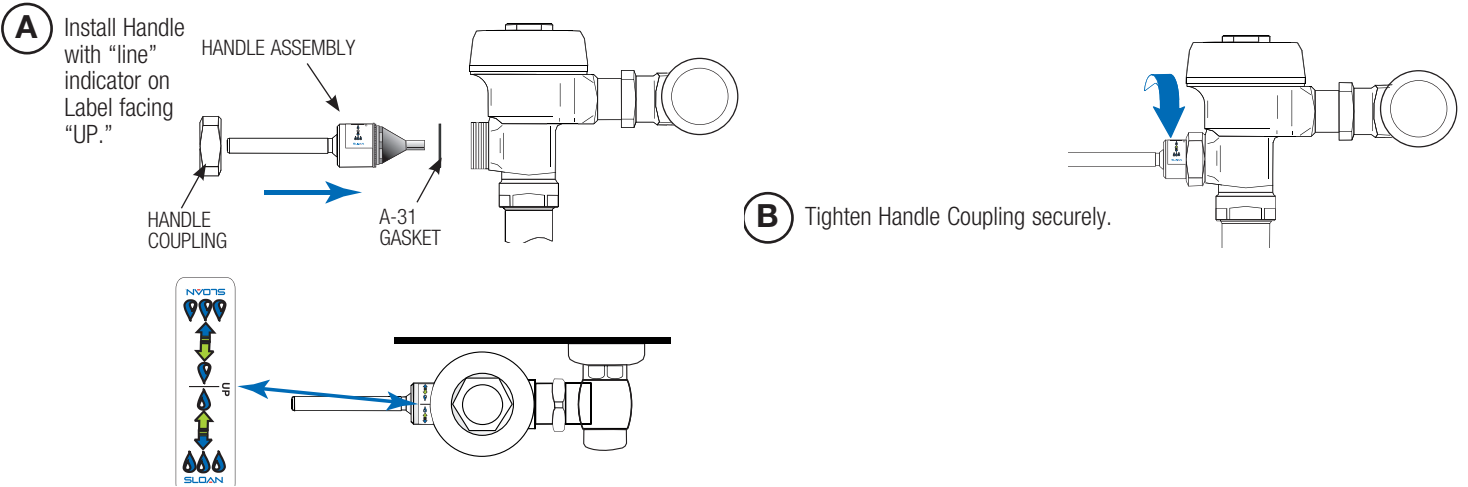

6 - FLUSH OUT SUPPLY LINE

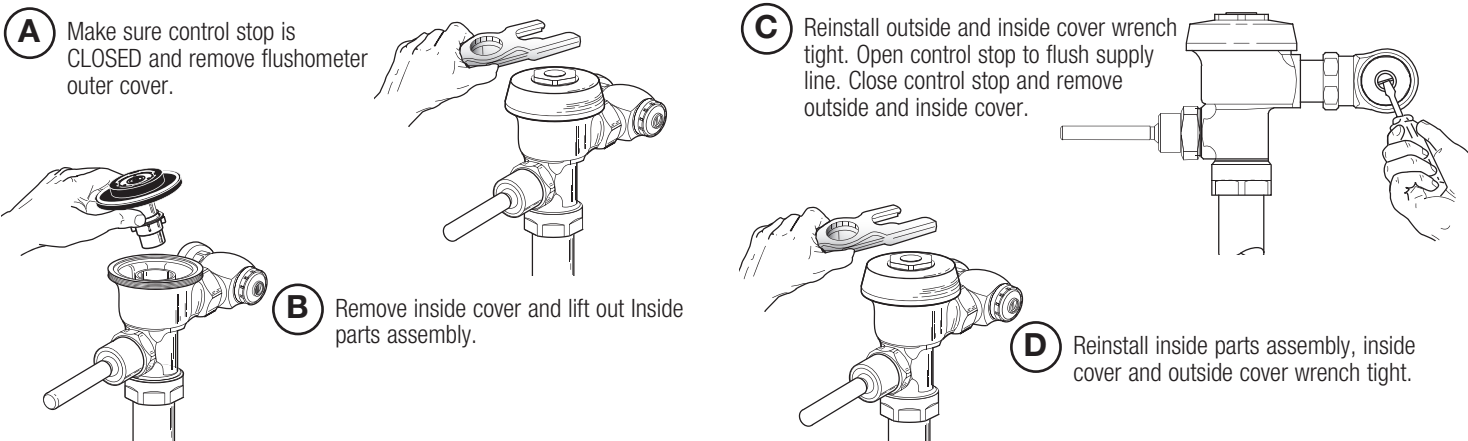

7 - ADJUST CONTROL STOP AND INSTALL VANDAL RESISTANT STOP CAP

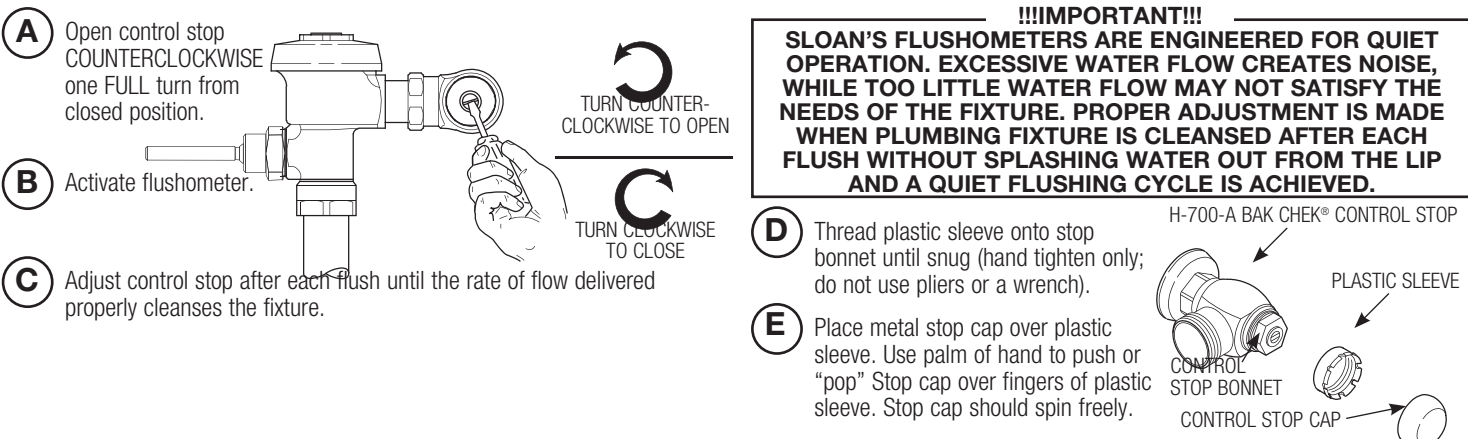

8 - INSTALL DUAL-FLUSH INSTRUCTION PLATES (RECOMMENDED PLATE LOCATIONS)

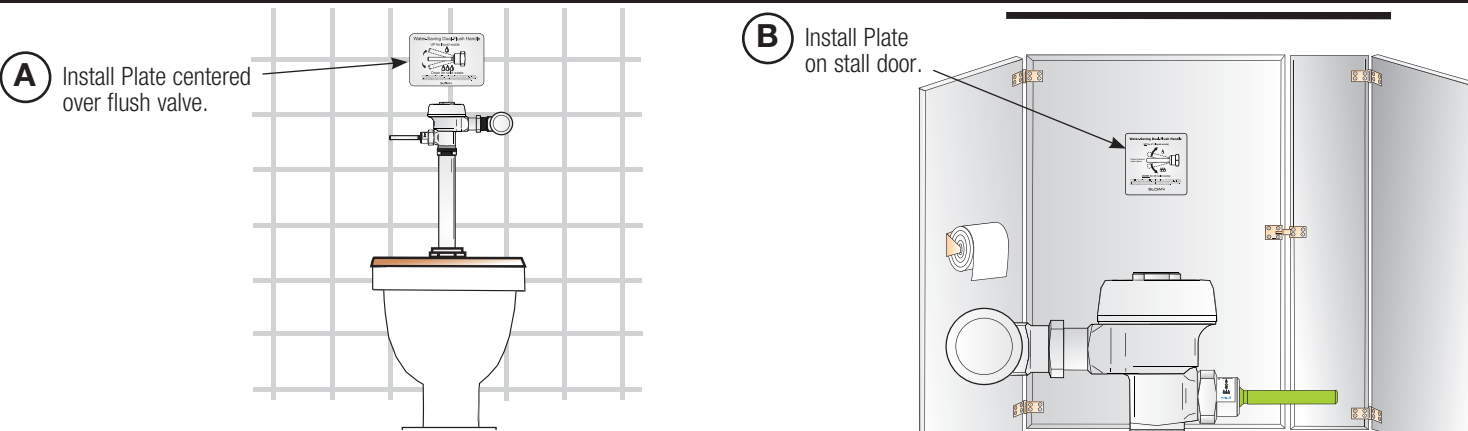

VANDAL RESISTANT CONTROL STOP CAP REMOVAL

Use a large flat screwdriver as a lever to remove the cap from the control stop. Insert the screwdriver blade between the bottom edge of the cap and the flat surface of the control stop body as shown. Push the screwdriver handle straight back toward the wall to gently lift the cap. If necessary, work the screwdriver around the diameter of the cap until you can grasp the cap and lift it completely off the sleeve. The sleeve should remain attached to the bonnet of the control stop.

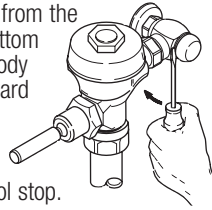

TROUBLESHOOTING GUIDE

1. Flushometer does not function (no flush).

- A. Control stop or main valve is closed. Open control stop or main valve.
- B. Handle assembly is damaged. Replace handle (WES-212).
- C. Relief valve is damaged. Replace performance kit.

2. Volume of water is not sufficient to siphon fixture.

- A. Control stop is not open wide enough. Adjust control stop for desired delivery of water volume.
- B. Dual-filtered diaphragm assembly is damaged. Replace performance kit.
- C. Incorrect dual-filtered diaphragm assembly is installed in flushometer; for instance, urinal assembly inside a closet flushometer, or low consumption assembly inside a higher consumption fixture. Determine the flush volume required by the fixture and replace performance kit. Use valve label and markings on fixture for reference.
- D. Water supply volume or pressure is inadequate. If no gauges are available to properly measure supply pressure or volume of water at the flushometer, then remove the relief valve from the dual-filtered diaphragm assembly, reassemble the flushometer and completely open the control stop.
 - If the fixture siphons, more water volume is required. Install a higher flushing volume performance kit. **IMPORTANT — LAWS AND REGULATIONS PROHIBIT THE USE OF HIGHER FLUSHING VOLUMES THAN LISTED ON FIXTURE OR FLUSHOMETER.**
 - If the fixture does not siphon or if a low consumption flush is required, steps must be taken to increase the water supply pressure and/or volume. Contact the fixture manufacturer for minimum water supply requirements of the fixture.

3. Length of flush is too short (short flush).

- A. Dual-filtered diaphragm assembly is damaged. Replace performance kit.
- B. Handle assembly is damaged. Replace handle (WES-212).

CARE AND CLEANING

DO NOT use abrasive or chemical cleaners (including chlorine bleach) to clean flushometers that may dull the luster and attack the chrome or special decorative finishes. Use ONLY mild soap and water, then wipe dry with clean cloth or towel.

While cleaning the bathroom tile, protect the flushometer from any splattering of cleaner. Acids and cleaning fluids will discolor or remove chrome plating.

- C. Incorrect dual-filtered diaphragm assembly is installed in flushometer; for instance, urinal assembly inside a closet flushometer, or low consumption assembly inside a higher consumption fixture. Determine the flush volume required by the fixture and replace performance kit. Use valve label and markings on fixture for reference.

4. Length of flush is too long (long flush) or continuous.

- A. Metering bypass hole in diaphragm is clogged. Remove the dual-filtered diaphragm assembly. Remove the primary and secondary filter rings from the diaphragm and wash under running water. Replace performance kit if cleaning does not correct the problem.
- B. Diaphragm or relief valve is damaged. Replace performance kit.
- C. Incorrect dual-filtered diaphragm assembly is installed in flushometer; for instance, closet assembly inside a urinal flushometer, or water saver assembly inside a low consumption flushometer. Determine the flush volume required by the fixture and replace the performance kit. Use valve label and markings on fixture for reference.
- D. Inside cover is damaged. Replace inside cover (A-71).
- E. Supply line water pressure has dropped and is not sufficient to close the valve. Close control stop until pressure is restored.

5. Chattering noise is heard during flush.

- A. Inside cover is damaged. Replace inside cover (A-71).

6. Handle Leaks.

- A. Handle seal or assembly is damaged. Replace handle (WES-212).

If assistance is required, please contact Sloan Technical Support at:

1-888-SLOAN-14 (1-888-756-2614)

or visit us online at: www.sloanvalve.com

PARTS LIST

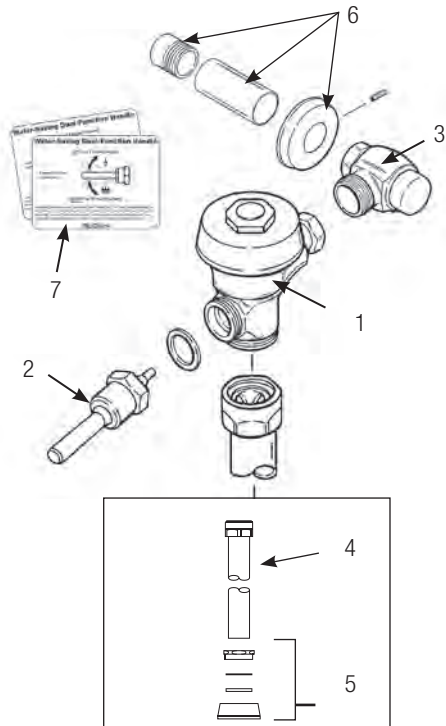

Item No.	Part No.	Description
1	†	Valve Assembly
2	WES-212	ADA Compliant Dual-Flush Handle Assembly
3	H-700-A	Bak-Chek® Control Stop
4	V-600-AA	1-1/2" (38 mm) x 9" (229 mm) Vacuum Breaker Assembly ‡
5	F-5-A	1-1/2" (38 mm) Spud Coupling Assembly
6	H-633-AA	1" (25 mm) Sweat Solder Kit with Cast Set Screw Flange
7	WES-13	Wall Plates (2) – English
	WES-18	Wall Plates (2) – Spanish
†		Part number varies with valve model variation; consult factory.
‡		Length varies with valve model variation; consult factory.

For optimum water conservation and flushometer performance, use only Genuine Sloan Parts.

Manufactured in the U.S.A. by Sloan Valve Company under one or more of the following patents: U.S. Pats. 5,295,655; 5,505,427; 5,542,718; 5,558,120; 5,564,460; 5,649,686; 5,730,415; 7,607,635. Other Pats. Pending. BAK-CHEK®, PARA-FLO®, PERMEX®, TURBO-FLO®. Additional patent(s) pending.

NOTE: The information contained in this document is subject to change without notice.

SLOAN HEADQUARTERS • 10500 SEYMOUR AVENUE • FRANKLIN PARK, IL 60131

Phone: 1-800-9-VALVE-9 • Fax: 1-800-447-8329 or 1-847-671-4380 • www.sloanvalve.com